

Please check the examination details below before entering your candidate information

Candidate surname

Other names

Centre Number

Candidate Number

--	--	--	--	--

--	--	--	--	--

Pearson Edexcel International GCSE

Friday 19 May 2023

Morning (Time: 2 hours)

Paper
reference

4MA1/1F

Mathematics A

PAPER 1F

Foundation Tier



You must have: Ruler graduated in centimetres and millimetres, protractor, pair of compasses, pen, HB pencil, eraser, calculator. Tracing paper may be used

Total Marks

Instructions

- Use **black** ink or ball-point pen.
- **Fill in the boxes** at the top of this page with your name, centre number and candidate number.
- Answer **all** questions.
- Without sufficient working, correct answers may be awarded no marks.
- Answer the questions in the spaces provided
– *there may be more space than you need.*
- **Calculators may be used.**
- You must **NOT** write anything on the formulae page.
Anything you write on the formulae page will gain **NO** credit.

Information

- The total mark for this paper is 100.
- The marks for **each** question are shown in brackets
– *use this as a guide as to how much time to spend on each question.*

Advice

- Read each question carefully before you start to answer it.
- Check your answers if you have time at the end.

Turn over ►

P72788A

©2023 Pearson Education Ltd.
N:1/1/1/



P 7 2 7 8 8 A 0 1 2 8



Pearson

International GCSE Mathematics
Formulae sheet – Foundation Tier

Area of trapezium = $\frac{1}{2}(a + b)h$

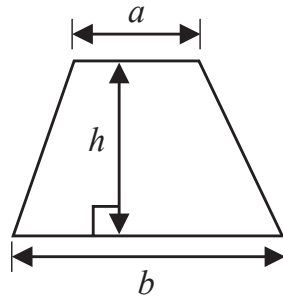

Volume of prism = area of cross section \times length

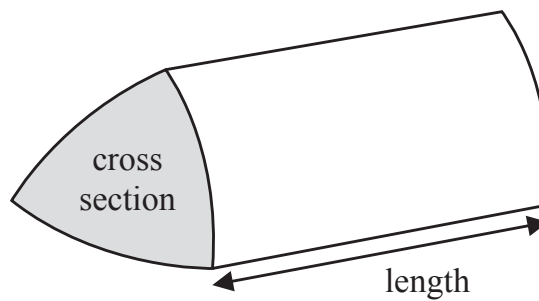

Volume of cylinder = $\pi r^2 h$

Curved surface area of cylinder = $2\pi r h$

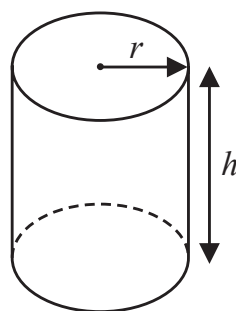

Answer ALL TWENTY FOUR questions.

Write your answers in the spaces provided.

You must write down all the stages in your working.

- 1 (a) Shade $\frac{4}{5}$ of this shape.

$$\frac{4}{5} \times 15 = 12$$

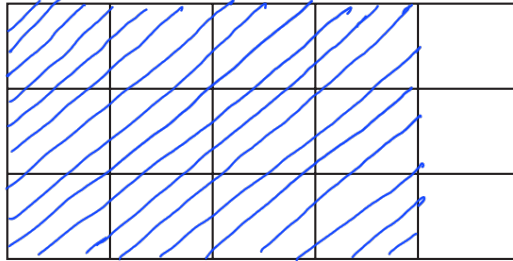

(1)

(1)

- (b) Write $\frac{27}{36}$ as a fraction in its simplest form.

$$\frac{27 \div 9}{36 \div 9} = \frac{3}{4} \quad (1)$$

$\frac{3}{4}$

(1)

- (c) Write $\frac{3}{100}$ as a decimal.

0.03 (1)

(1)

- (d) Write $\frac{7}{50}$ as a percentage.

$$\frac{7}{50} \times 100\% = 14\% \quad (1)$$

14

%

(1)

(Total for Question 1 is 4 marks)

- 2 Melanie finds this information about the number of people, in millions, who speak each of five languages as their first language.

Language	Number of people (in millions)
Spanish	480
Greek	13
Mandarin Chinese	918
Tamil	75
Japanese	128

- (a) Which of these languages is the first language of the greatest number of people?

Mandarin chinese (1)

(1)

More people speak Japanese as their first language than speak Greek as their first language.

- (b) How many more? $128 - 13 = 115$

115 (1) million

(1)

The number of people who speak Tamil as their first language is $\frac{1}{4}$ of the number of people who speak Bengali as their first language.

- (c) Work out the number of people who speak Bengali as their first language.

$$75 \times 4 = 300 \quad (1)$$

300 million

(1)

It is estimated that 861 700 people can speak Welsh.

- (d) Write 861 700 in words.

Eight hundred and sixty one thousand , seven hundred . (1)

(1)

(Total for Question 2 is 4 marks)

3 Ivor asks 20 children in his class to name their favourite fruit. Here are his results.

~~apple~~ ~~orange~~ ~~grape~~ ~~peach~~ ~~grape~~
~~banana~~ ~~apple~~ ~~orange~~ ~~grape~~ ~~peach~~
~~apple~~ ~~apple~~ ~~banana~~ ~~peach~~ ~~orange~~
~~grape~~ ~~orange~~ ~~apple~~ ~~orange~~ ~~orange~~

(a) Complete the frequency table to show this information.

Fruit	Tally	Frequency
apple		5
banana		2
grape		4
peach		3
orange	(1)	6 (1)

(2)

(b) Complete the bar chart for the information in your table.

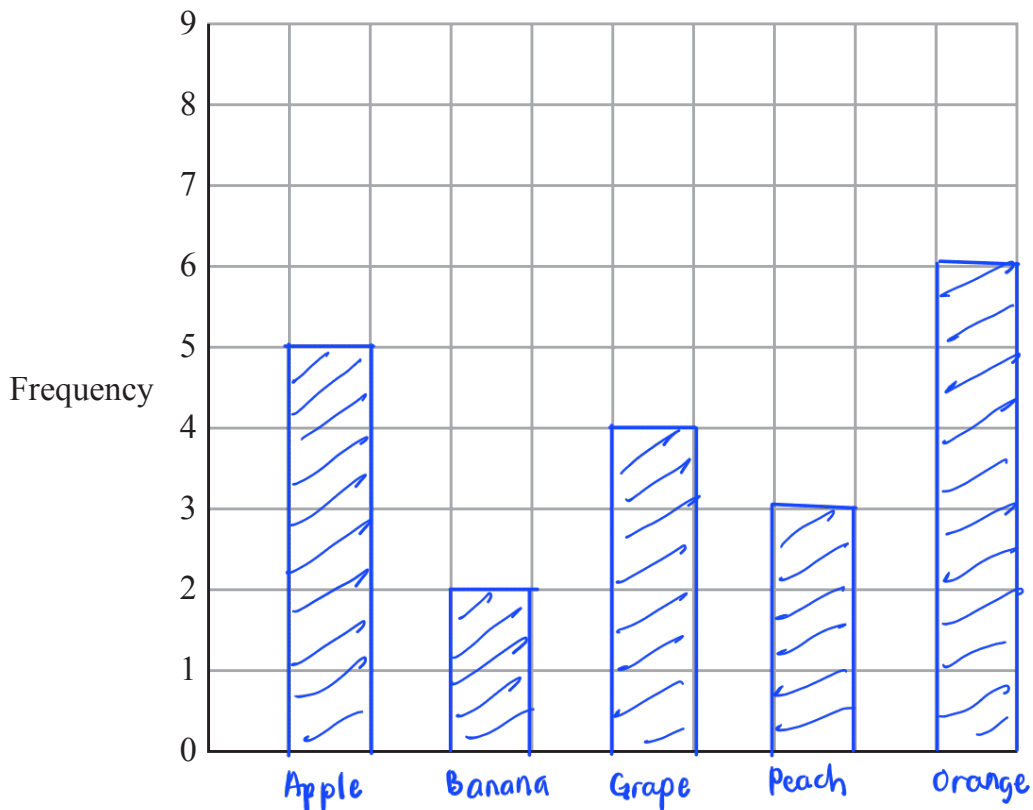

(3)

(3)

(Total for Question 3 is 5 marks)

4 (a) Write 4.15 pm as a time using the 24-hour clock.

16 15 (1)

(1)

On Thursday, Belina drives to Theo's house.

She leaves home at 09 15

She arrives at Theo's house at 14 40

(b) Work out how long the journey takes.
Give your answer in hours and minutes.

$$\begin{array}{r} 14\ 40 \\ -\ 09\ 15 \\ \hline 5\ 25 \\ \hline \end{array}$$

5 hours 25 minutes
(2)

(Total for Question 4 is 3 marks)

5 (a) Simplify $p + p + p + p$

$$4p \quad \textcircled{1}$$

.....
(1)

(b) Simplify $5e + 6f + 7e - 2f$

$$\begin{aligned} &5e + 7e + 6f - 2f \\ &= 12e + 4f \end{aligned}$$

$$12e + 4f \quad \textcircled{2}$$

.....
(2)

(c) Solve $13 - x = 7$

$$\begin{aligned} x &= 13 - 7 \\ &= 6 \end{aligned}$$

$$x = 6 \quad \textcircled{1}$$

.....
(1)

(d) Solve $4y + 7 = 43$

$$\begin{aligned} 4y &= 43 - 7 \quad \textcircled{1} \\ 4y &= 36 \\ y &= \frac{36}{4} = 9 \quad \textcircled{1} \end{aligned}$$

$$y = 9$$

.....
(2)

(Total for Question 5 is 6 marks)

6 Vivienne makes bread.

The weight of yeast she uses is 1% of the weight of flour she uses.

Vivienne uses 750 g of flour.

(a) Work out the weight of yeast she uses.

$$0.01 \times 750 \text{ g} = 7.5 \text{ g}$$

(1) (1)

$$\begin{array}{r} 7.5 \\ \hline \end{array} \text{ g}$$

(2)

Bernard makes currant buns.

For every 400 g of flour he uses, he uses 125 g of currants.

Bernard uses 2000 g of flour.

(b) Work out the weight of currants he uses.

$$\begin{aligned} \text{weight of currants used} &: \frac{2000}{400} \times 125 \text{ g} \quad (1) \\ &= 625 \text{ g} \quad (1) \end{aligned}$$

$$\begin{array}{r} 625 \\ \hline \end{array} \text{ g}$$

(2)

(Total for Question 6 is 4 marks)

7 The diagram shows a rectangle measuring 10 cm by 3 cm.

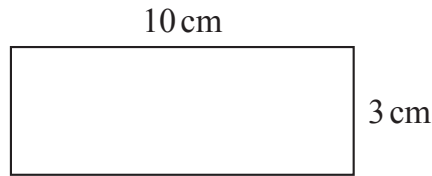
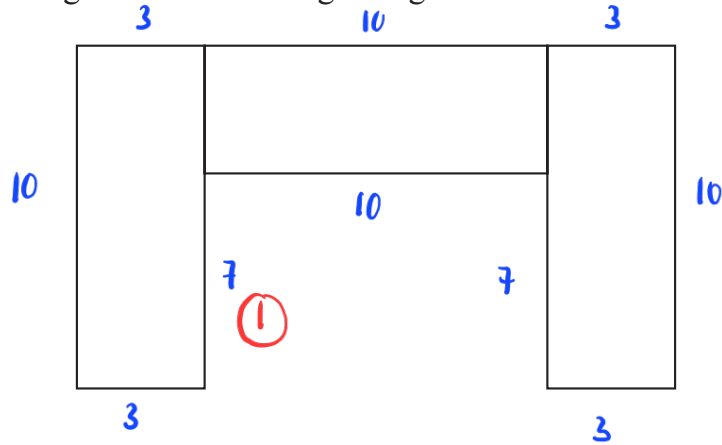

Diagram **NOT** accurately drawn

A shape is made by placing 3 of these rectangles together as shown in the diagram.



Work out the perimeter of the shape.

$$\begin{aligned} \text{Perimeter} &= 10 + 3 + 7 + 10 + 7 + 3 + 10 + 3 + 10 + 3 \quad (1) \\ &= 66 \quad (1) \end{aligned}$$

66 cm

(Total for Question 7 is 3 marks)

- 8 Carla wraps some parcels with ribbon.
She wraps 2 large parcels and 3 small parcels.

For each large parcel, Carla uses 185 centimetres of ribbon.
For each small parcel, she uses p centimetres of ribbon.

In total, Carla uses exactly 7 metres of ribbon to wrap the parcels.

Find the value of p

$$2(185) + 3p = 7(100) \quad (1)$$

$$370 + 3p = 700$$

$$3p = 330 \quad (1)$$

$$p = \frac{330}{3} = 110 \text{ cm} \quad (1)$$

$$p = \dots\dots\dots 110 \text{ cm}$$

(Total for Question 8 is 3 marks)

9 Here is a number machine.

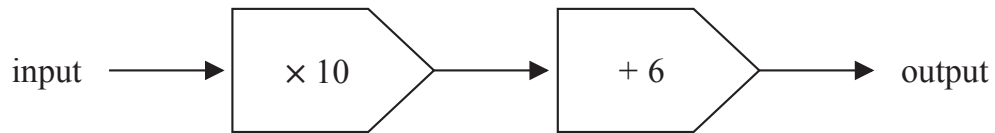

(a) Work out the output when the input is 14

$$14 \times 10 + 6 \\ = 146 \quad (1)$$

146

(1)

Here is a different number machine.

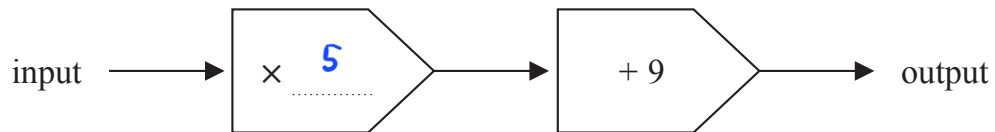

When the input is 11 the output is 64

(b) Write a number on the dotted line to complete the number machine.

$$11 \times m + 9 = 64 \quad (1)$$

$$11m = 55$$

$$m = \frac{55}{11} = 5 \quad (1)$$

(2)

(Total for Question 9 is 3 marks)

10 There are 30 counters in a bag.

13 of the counters are purple.

11 of the counters are white.

The rest of the counters are red.

Suha takes at random a counter from the bag.

(a) Write down the probability that the counter is purple.

$$\frac{13}{30} \quad (1)$$

(1)

(b) Work out the probability that the counter is red.

$$\text{red} = 30 - 13 - 11 = 6$$

$$\frac{6}{30} \quad (1)$$

$$\frac{6}{30}$$

(1)

The counter is put back into the bag.

Clive now puts 10 more counters into the bag.

When a counter is taken at random from the bag,

the probability that it is white is now $\frac{2}{5}$

(c) How many of the 10 counters that Clive puts into the bag are white?

$$\text{Total counters} : 30 + 10 = 40$$

$$\frac{2}{5} \times 40 = 16 \quad (1)$$

$$16 - 11 = 5 \quad (1)$$

5

(2)

(Total for Question 10 is 4 marks)

11 Pablo buys some tickets to go to the theatre.

3 of the tickets are for adults.

The remaining tickets are for children.

Each adult ticket costs 12 euros.

The children's tickets each cost 30% less than an adult ticket.

The total amount of money that Pablo pays for all the tickets is 94.80 euros.

Find the number of children's tickets Pablo buys.

$$\text{price of each children's ticket} : 0.7 \times 12 = 8.40 \quad (1)$$

$$\therefore \text{let no. of children's ticket} = x$$

$$3(12) + 8.40x = 94.80$$

$$8.40x = 94.80 - 36$$

$$8.40x = 58.80 \quad (1)$$

$$x = \frac{58.80}{8.40} \quad (1)$$

$$= 7 \quad (1)$$

7

(Total for Question 11 is 4 marks)

12 Pam plays netball for her school team.

Here are the numbers of goals she scored in the last 8 games.
The numbers of goals are written in order of size.

1 1 2 2 3 6 x 14

(a) Find the range of the number of goals Pam scored.

$$14 - 1 = 13 \quad (1)$$

13

.....
(1)

(b) Find the median number of goals Pam scored.

$$\text{Median} = \frac{2+3}{2} = 2.5 \quad (1)$$

2.5

.....
(1)

The mean number of goals Pam scored in the 8 games is 5

(c) Work out the value of x

$$\text{Total goals scored} = 8 \times 5 = 40 \quad (1)$$

$$x = 40 - 1 - 1 - 2 - 2 - 3 - 6 - 14 \quad (1)$$

$$= 40 - 29$$

$$= 11 \quad (1)$$

$$x = \dots\dots\dots 11 \quad (3)$$

(Total for Question 12 is 5 marks)

13 The diagram shows a rectangle and an isosceles triangle.

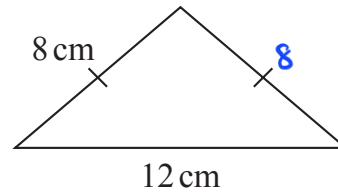
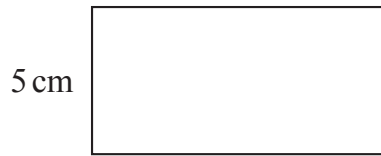

Diagram **NOT** accurately drawn

The perimeter of the rectangle is equal to the perimeter of the triangle.

(a) Find the area of the rectangle.

$$\text{Perimeter} = 8 + 8 + 12 = 28 \quad (1)$$

$$\text{Side length} = \frac{28 - 5(2)}{2} = 9$$

$$\text{Area} = 9 \times 5 = 45 \quad (1)$$

$$\dots\dots\dots 45 \dots\dots\dots \text{cm}^2$$

(3)

The diagram shows a cuboid.

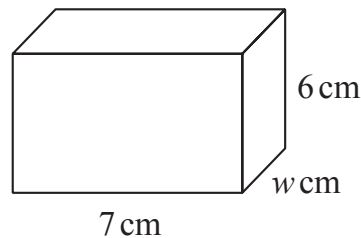

Diagram **NOT** accurately drawn

The volume of the cuboid is 231 cm^3

(b) Calculate the value of w

$$7 \times 6 \times w = 231$$

$$42w = 231$$

$$w = \frac{231}{42} = 5.5 \quad (1)$$

$$w = \dots\dots\dots 5.5 \dots\dots\dots$$

(2)

(Total for Question 13 is 5 marks)

14 (a) Work out the value of $\frac{9}{12.4} + \frac{5.3 \times 2.8}{9.64}$

Give your answer as a decimal.

Write down all the figures on your calculator display.

$$0.72580645.. + 1.53941909... \text{ (1)}$$

$$= 2.26522554 \text{ (1)}$$

$$2.26522554$$

(2)

(b) Write your answer to part (a) correct to 3 significant figures.

(1)

$$2.27$$

(1)

(Total for Question 14 is 3 marks)

15 $\mathcal{E} = \{5, 6, 7, 8, 9, 10, 11, 12, 13, 14, 15, 16, 17, 18, 19, 20\}$

$A = \{\text{odd numbers}\}$

$B = \{\text{multiples of 5}\}$

Complete the Venn diagram for this information.

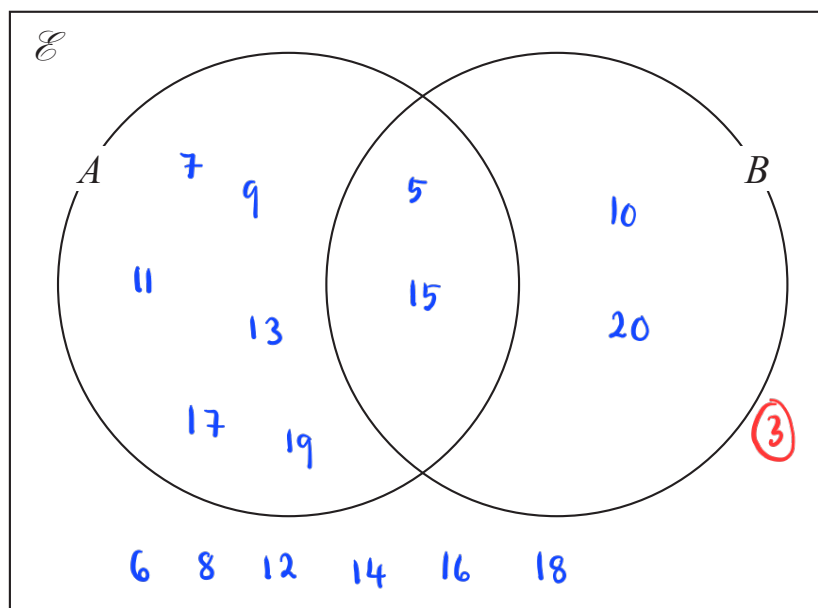

(Total for Question 15 is 3 marks)

16 Last season, the number of goals scored by Arjun, by Simon and by Kath for their football team were in the ratios 2:5:8

Simon scored 12 more goals than Arjun.

Work out the number of goals scored by Kath.

$$\text{difference in ratio : } 5 - 2 = 3$$

$$1 \text{ ratio equals to } = \frac{12}{3} = 4 \text{ goals}$$

①

$$\text{Kath scores : } 8 \times 4 = 32 \text{ goals}$$

① ①

32

(Total for Question 16 is 3 marks)

- 17 The table gives information about the number of minutes that Abby spent walking each day in September.

Number of minutes (M)	Frequency
$0 < M \leq 30$	5
$30 < M \leq 60$	6
$60 < M \leq 90$	8
$90 < M \leq 120$	9
$120 < M \leq 150$	2

Work out an estimate for the total number of minutes that Abby spent walking in September.

$$\begin{aligned}\text{Estimated total} &: (15 \times 5) + (45 \times 6) + (75 \times 8) + (105 \times 9) + (135 \times 2) \quad (1) \\ &= 75 + 270 + 600 + 945 + 270 \quad (1) \\ &= 2160 \quad (1)\end{aligned}$$

2160

..... minutes

(Total for Question 17 is 3 marks)

18 Nanette buys 60 notebooks for a total cost of 780 dirhams.

Nanette sells 70% of the notebooks for 22 dirhams each.
She sells the remaining notebooks for 19 dirhams each.

Work out Nanette's percentage profit.
Give your answer correct to 3 significant figures.

$$\frac{70}{100} \times 60 = 42$$

$$\begin{aligned} \text{Nanette sells: } & 42 \times 22 + (60 - 42) \times 19 \\ & = 924 + 342 \text{ (1)} \\ & = 1266 \text{ (1)} \end{aligned}$$

$$\text{Percentage profit: } \frac{1266 - 780}{780} \times 100\% \text{ (1)}$$

$$= \frac{486}{780} \times 100\%$$

$$= 62.3\% \text{ (1)}$$

62.3 %

(Total for Question 18 is 4 marks)

19 The diagram shows a sketch of triangle **A** and triangle **B** on a coordinate grid.

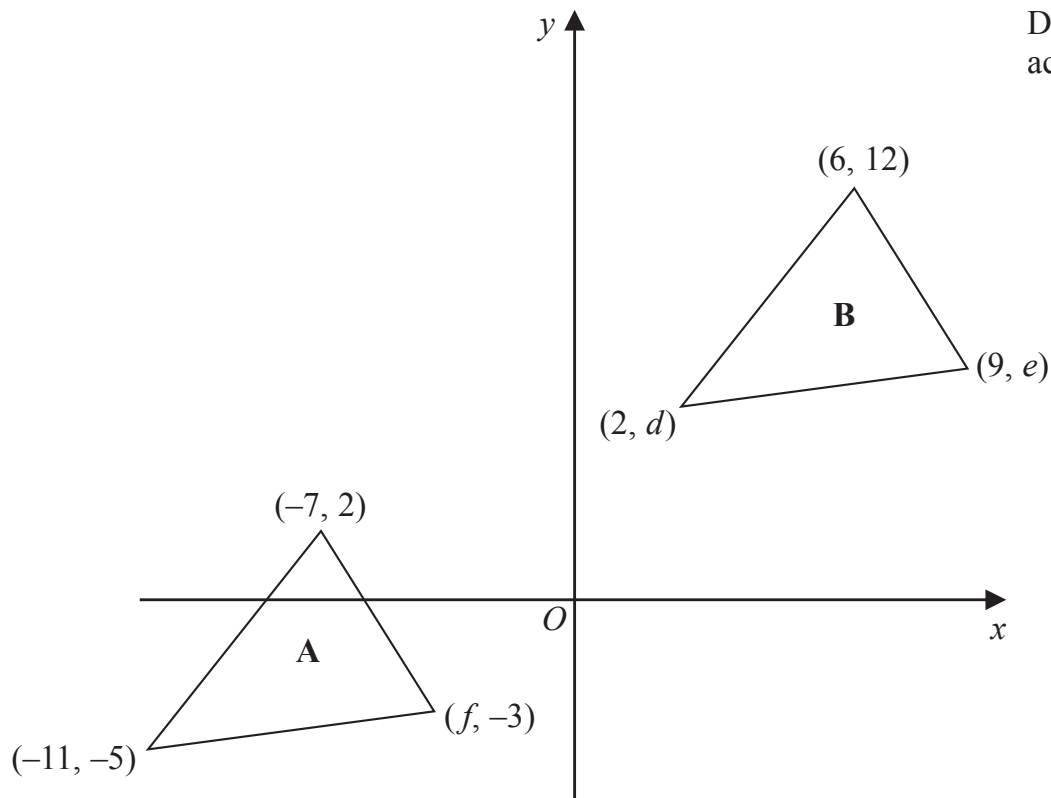

Diagram **NOT** accurately drawn

- (a) Given that triangle **A** has been translated to give triangle **B**, work out the value of d , the value of e and the value of f

$$\begin{aligned} \text{translation} &= \begin{pmatrix} 6 - (-7) \\ 12 - 2 \end{pmatrix} \\ &= \begin{pmatrix} 13 \\ 10 \end{pmatrix} \quad (1) \end{aligned}$$

$$\begin{aligned} \text{point } (-11, -5) &: \begin{pmatrix} -11 + 13 \\ -5 + 10 \end{pmatrix} \\ &= \begin{pmatrix} 2 \\ 5 \end{pmatrix} \quad \therefore d = 5 \quad (1) \end{aligned}$$

$$\begin{aligned} \text{point } (f, -3) &: \begin{pmatrix} f + 13 \\ -3 + 10 \end{pmatrix} = \begin{pmatrix} 9 \\ e \end{pmatrix} \\ f &= 9 - 13 = -4 \\ e &= -3 + 10 = 7 \end{aligned}$$

$$\begin{aligned} d &= \dots 5 \quad (1) \\ e &= \dots 7 \\ f &= \dots -4 \\ & \quad (3) \end{aligned}$$

The diagram shows shape **P** and shape **Q** drawn on a grid.

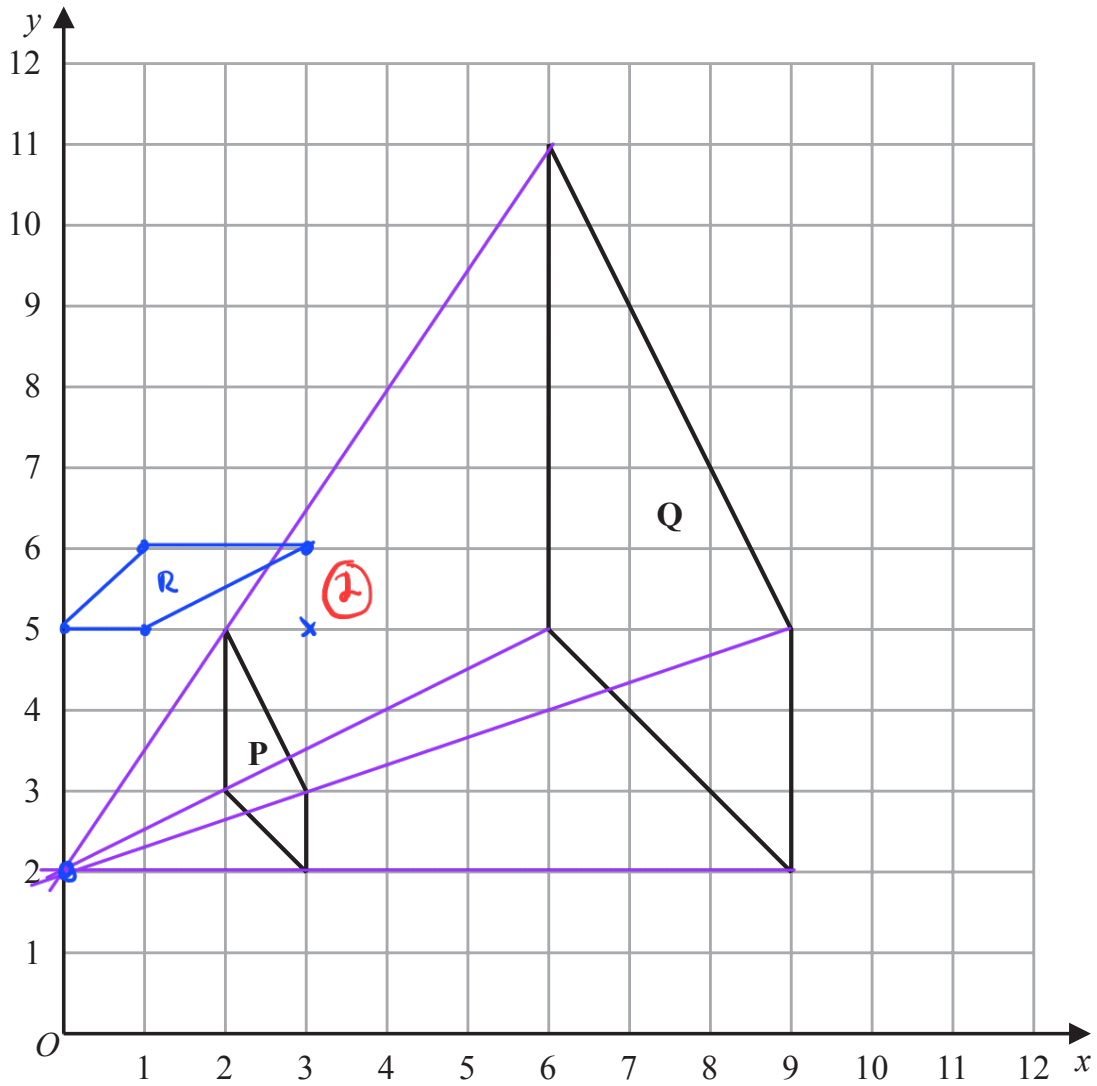

(b) Describe fully the single transformation that maps shape **P** onto shape **Q**

Enlargement of scale factor 3 at centre $(0, 2)$

①

①

①

(3)

(c) On the grid above, rotate shape **P** 90° clockwise about $(3, 5)$
Label your shape **R**

(2)

(Total for Question 19 is 8 marks)

- 20 The diagram shows a shaded shape $AEBCD$ made by removing triangle AEB from rectangle $ABCD$

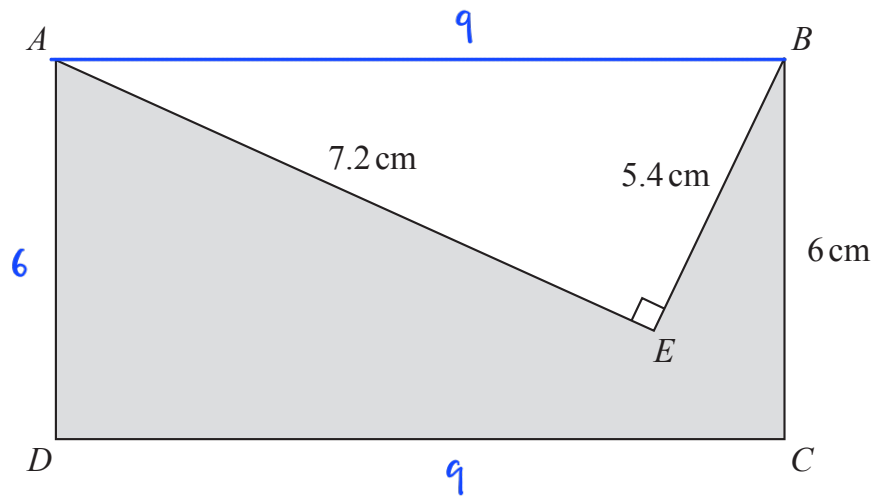

Diagram NOT accurately drawn

$$AE = 7.2 \text{ cm} \quad BE = 5.4 \text{ cm} \quad BC = 6 \text{ cm} \quad \text{angle } AEB = 90^\circ$$

Work out the perimeter of the shaded shape.

$$AB^2 = 7.2^2 + 5.4^2$$

$$= 81 \quad (1)$$

$$AB = \sqrt{81} = 9 \quad (1)$$

$$\text{Perimeter} = 6 + 7.2 + 5.4 + 6 + 9 \quad (1)$$

$$= 33.6 \quad (1)$$

..... 33.6 cm

(Total for Question 20 is 4 marks)

21 (a) Simplify $(2c^4d^7)^3$

$$\begin{aligned} & 2^3 \times c^{4 \times 3} \times d^{7 \times 3} \\ & = 8c^{12}d^{21} \end{aligned}$$

$$\frac{8c^{12}d^{21}}{(2)}$$

(b) Find the value of $5y^0$ where $y > 0$

$$\begin{aligned} & y^0 = 1 \\ & 5(1) = 5 \quad (1) \end{aligned}$$

$$\frac{5}{(1)}$$

(c) Factorise fully $16a^2b^3 + 20a^3b$

$$\begin{aligned} & 4(4a^2b^3 + 5a^3b) \\ & 4a^2(4b^3 + 5ab) \\ & 4a^2b(4b^2 + 5a) \quad (2) \end{aligned}$$

$$\frac{4a^2b(4b^2 + 5a)}{(2)}$$

(d) (i) Factorise $x^2 + 9x - 22$

$$\begin{aligned} & (x + 11)(x - 2) \quad (1) \\ & = (x + 11)(x - 2) \quad (1) \end{aligned}$$

$$\frac{(x + 11)(x - 2)}{(2)}$$

(ii) Hence solve $x^2 + 9x - 22 = 0$

$$\frac{-11, 2 \quad (1)}{(1)}$$

(Total for Question 21 is 8 marks)

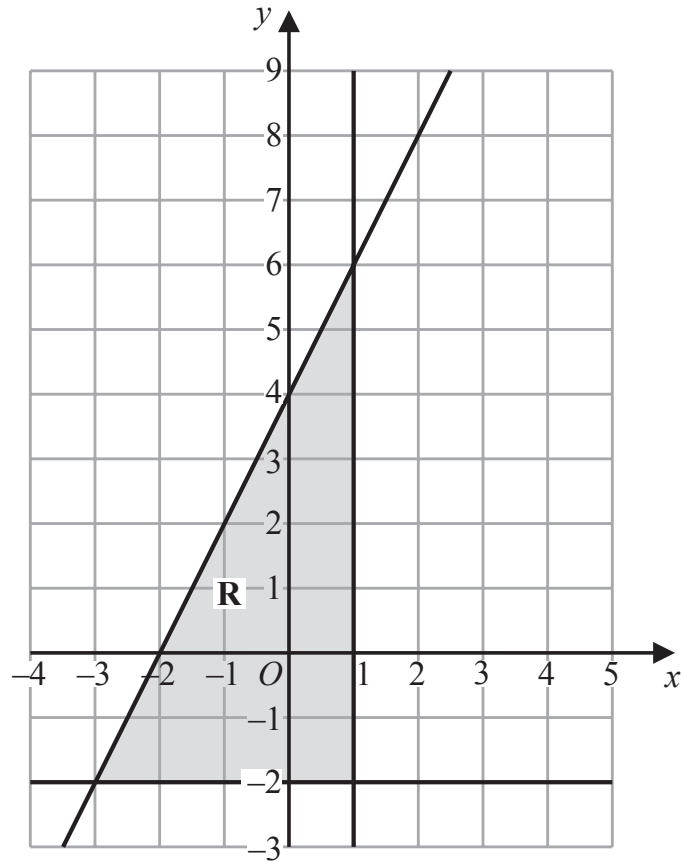

The region **R**, shown shaded in the diagram, is bounded by three straight lines.

Find the inequalities that define **R**

$$\text{Take point } (1, 6) : 6 = m(1) + 4$$

$$m = 2$$

$$y = 2x + 4$$

①

$$x \leq 1 \quad \text{①}$$

$$y \geq -2 \quad \text{①}$$

$$y \leq 2x + 4 \quad \text{①}$$

(Total for Question 22 is 4 marks)

- 23 (a) Write 300 as a product of its prime factors.
Show your working clearly.

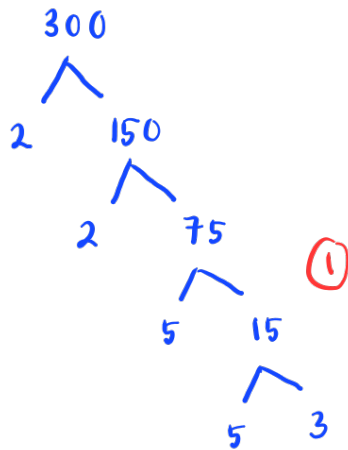

$$2 \times 2 \times 3 \times 5 \times 5 = 300$$

(1)

$$2 \times 2 \times 3 \times 5 \times 5$$

(2)

$$A = 2 \times 2 \times 2 \times 3 \times 3 \times 5$$

$$B = 2 \times 2 \times 3 \times 3 \times 3 \times 5$$

- (b) Find the lowest common multiple (LCM) of $5A$ and $7B$
Show your working clearly.

$$5A : 2^3 \times 3^2 \times 5^2 = 1800$$

(1)

$$7B : 2^2 \times 3^3 \times 5 \times 7 = 3780$$

$$\text{LCM of } 5A \text{ and } 7B = 2^3 \times 3^3 \times 5^2 \times 7$$

$$= 8 \times 27 \times 25 \times 7$$

$$= 37800$$

(1)

$$37800$$

(2)

(Total for Question 23 is 4 marks)

24 Solve the simultaneous equations

$$2x + 9y = 14.5 \quad \text{--- (1)}$$

$$7x + 3y = 8$$

$$\begin{array}{r} \times 3 \downarrow \\ 21x + 9y = 24 \quad \downarrow \times 3 \\ \text{--- (2)} \end{array}$$

Show clear algebraic working.

$$\text{(2)} - \text{(1)} :$$

$$21x - 2x + 9y - 9y = 24 - 14.5$$

$$19x = 9.5 \quad \text{(1)}$$

$$x = \frac{9.5}{19} = \frac{1}{2}$$

$$2\left(\frac{1}{2}\right) + 9y = 14.5 \quad \text{(1)}$$

$$1 + 9y = 14.5$$

$$9y = 13.5$$

$$y = \frac{13.5}{9} = 1.5$$

$$x = \dots\dots\dots 0.5 \quad \text{(1)}$$

$$y = \dots\dots\dots 1.5$$

(Total for Question 24 is 3 marks)

TOTAL FOR PAPER IS 100 MARKS

BLANK PAGE

BLANK PAGE